

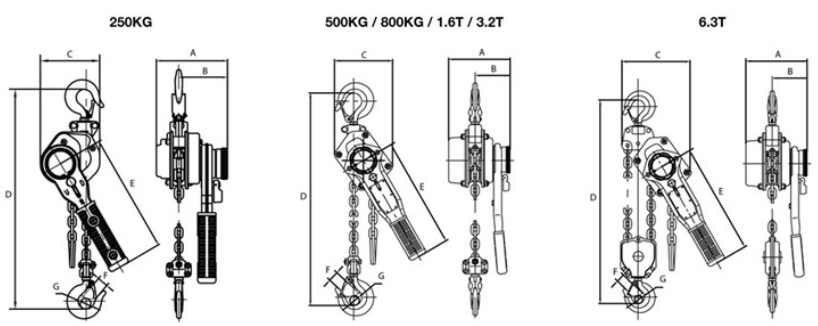

Now with Heavy Duty Hook Latch



- Features: -**
- Compact design and robust, deep drawn, stamped steel construction.
 - High quality materials ensure light weight without infringing reliability.
 - Low weight, small mounting sizes and small lever forces at full load.
 - Hand lever operates with little effort due to optional gear ratio.
 - Premium grade alloy load chain.
 - Drop-forged and expertly heat treated hooks for great strength and long wearing
 - Capacity ranges from 0.75 ton to 6.2 ton.
 - Different lifting length is available at requirement



Capacity	tons	0.25	0.5	0.75	1	1.5	2	3	6	9
Standard lift	m	1.5	1.5	1.5	1.5	1.5	1.5	1.5	1.5	1.5
Running test load	KN	3.75	7.5	11.25	15	22.5	30	45	90	112.5
Effort required to lift rated load	N	250	340	140	185	234	251	362	362	360
Strands of load chain		1	1	1	1	1	1	1	2	3
Diameter of load chain	mm	4	5	6	6	7.1	8	10	10	10
Dimensions (mm)	A	92	105	152	152	175	175	195	195	215
	B	72	78	95	95	110	105	110	115	130
	C	85	80	128	128	148	160	181	232	330
	D	30	35	36	36	43	46	50	65	85
	H	230	260	295	295	335	385	450	542	700
	L	160	300	256	256	368	368	368	368	410
	K	25	25	26	26	33	36	37	50	58
Net weight	kg	1.8	4	7	7	11	15.5	20	28	47
Packing measurement	cm	20x7.5x9	33x12x9	33x16x13	33x16x13	43x18.5x16	44x19x17	50x20x18	53x21x21	82x32x21.5
Extra weight per metre of extra lift	kg	0.34	0.54	0.8	0.8	1.1	1.4	2.2	4.4	6.6



POWERED BY **ARMSTRONG INDUSTRIES LIMITED (USA)**



For OSHA, ASME B30.9 and Manufacturer's Guidelines. Can fall if damaged, misused or overload. Inspect before use. Use only if trained. Do not exceed rated capacity. Protect from contact with edges. DEATH or INJURY can occur from improper use or maintenance